

Don't Just Rebuild it ... Improve it ! One Complete Kit Does it All

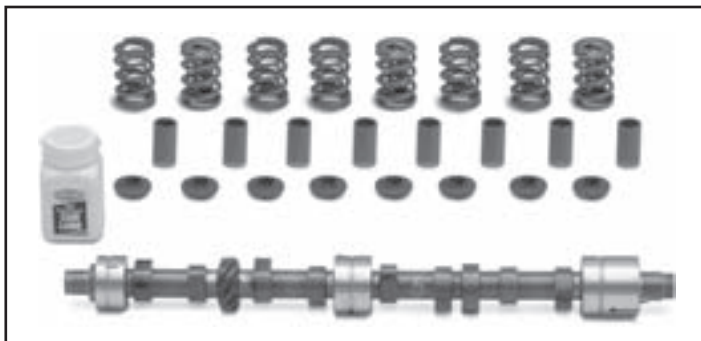

All Kent Camshafts are high lift - high torque - wide power band cams with phenomenal mid-range and top end power. They are precision reground to the highest standard using the most current technological equipment.

They will operate at maximum efficiency and satisfaction, only when installed properly in the correct application.

Assembly Tip:

You must use cam lube on camshaft and cam lifters before assembly to prevent scuffing during initial start-up.

Road Speed Grind: To put you way out in front and still have a smooth idle at a light.

Contents of kits were specially selected so that all components are compatible and will fit without additional machining necessary.

Kent Camshaft Kit Includes:

- Kent Performance Camshaft
- Lifters
- Cam Lubricant
- Valve Springs

PART	DESCRIPTION AND APPLICATION	REQD	LIST	SELL
17-159	ROAD CAM KIT 2000-6500 SPITFIRE 67-72 (1)	1	599.94	479.95
1-355	CAM BEARING SET SPITFIRE 67-72 (1)	1	31.19	24.95
17-158	ROAD CAM KIT 2000-6500 "A" SPITFIRE 73-80 (1)	1	599.94	479.95

Note: "A" #17-158 Camshaft Kit for the Spitfire 1973-80 is for non-bearing camshafts. #17-159 Camshaft Kit for the 1967-72 Spitfires that use auxiliary bearings. Bearings not included.

VICTORIA BRITISH LTD., The Exclusive Mid-American Distributor

Not legal for sale or use on pollution controlled vehicles.

Made in England

PART # INT/EXH	POWER BAND INT/EXH	CAM LIFT INT/EXH	VALVE LIFT FIGURES	DURATION @ FULL LIFT	TIMING INT/EXH	INLET TIMING	VLV/CLRNC
17-158 Road	2000-6500	.261"	.382" .378"	.295°	39/76 76/39	108°	.014" .018"
17-159 Road		6.62mm	9.69mm 9.59mm				0.36mm 0.46mm

Kent Cam Sprockets for Razor Sharp Timing

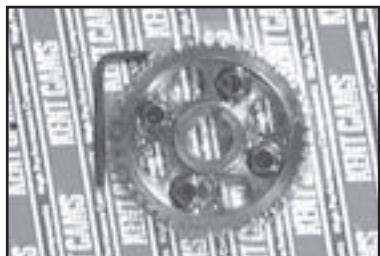

Made in England

The Adjustable Cam Sprocket allows precise indexing of the camshaft with just the touch of a dial while it's still on the car. Solid Steel Cam Sprockets are more durable and lighter than the original cast iron sprockets that came on your car.

PART	DESCRIPTION AND APPLICATION	REQD	LIST	SELL
17-095	ADJUSTABLE CAM SPROCKET -DUAL GT6 66-73 (1)	1	312.44	249.95
17-100	SOLID STEEL CAM SPROCKET -DUAL GT6 63-73 (1)	1	81.19	64.95
17-101	SOLID STEEL CRANK SPROCKET-DUAL GT6 66-73 (1)	1	68.69	54.95
1-829	TIMING CHAIN -DUAL GT6 66-73 (1)	1	12.44	9.95

Extra Heavy-Duty Auto Dolly Set Makes Moving Your Car Easy

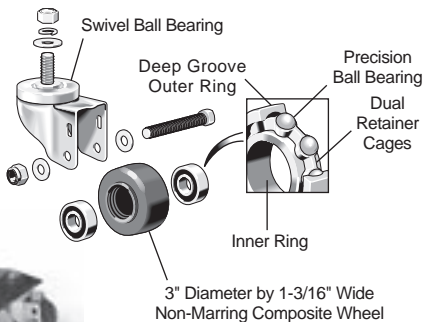

- XHD Auto Dolly Set makes it easy for one person to move a car, truck or SUV forward, backward or sideways into a tight spot.
- 7,000 lbs. rating means you can handle any car, SUV or truck up thru 3/4 ton pickups.
- Dolly platform painted black.
- 1/4" thick mild steel x 12" x 16" formed plate.
- Ball bearing caster wheels are 3" in diameter by 1-3/16" wide.
- Each non-marring composite caster has a swivel ball bearing and two deep groove ball bearings.
- Each dolly has one caster equipped with one locking safety brake.
- XHD Auto Dollies are only for use on level smooth surfaces.

*After the sell price means Oversize Part Charge. Your order will incur a charge of \$20.00 for each oversized part.

PART	DESCRIPTION AND APPLICATION	LIST	SELL
15-698	XHD AUTO DOLLY SET OF 4 7,000 LB CAPACITY	212.44	169.95 *

Sold as Set of 4

Steel Pushrods and Cam Lifters ... For Competition Use

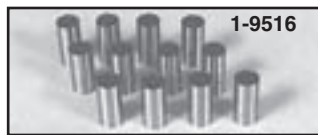

1-9516

Tubular Steel Pushrods have improved strength for competition use. Slightly shorter than standard to fit the high compression cylinder heads. Sold in sets.

Cam Lifters are specially lightened and hardened for improved life and reduced loading on the camshaft, to increase the rev band. Sold in sets.

PART	DESCRIPTION AND APPLICATION	REQD	LIST	SELL
1-9515	STEEL PUSHROD SET	SPITFIRE 67-80 (1)	187.44	149.95
1-9521	STEEL PUSHROD SET	GT6 66-73 (1)	262.44	209.95
1-9516	LIFTER SET	SPITFIRE 62-80 (1)	174.94	139.95

Rocker Spacer Set ... Improved Wear and Life



1-9518

The Rocker Spacer Set replaces spring tensioners on the standard rocker shaft assembly. They are solid and allow the rockers to rotate easier. Sold as a set of Spacers with Adjusting Washers.

PART	DESCRIPTION AND APPLICATION	REQD	LIST	SELL
1-9518	ROCKER SPACER SET-SOLID	GT6 66-73 (1)	87.44	69.95

Rocker Feed Kit ... Increases Oil Supply to Rocker Shaft

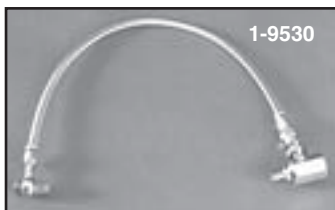

1-9530

This Rocker Feed Kit is designed to increase the supply of oil to the rocker shaft, eliminating some engine problem areas. This bolt-on kit comes complete for your convenience, saving you time and money. Call or go online and order yours today!

- Increases supply of oil to rocker shaft.
- Eliminates some problem areas on engine.
- Complete bolt-on kit for your convenience.

PART	DESCRIPTION AND APPLICATION	REQD	LIST	SELL
1-9530	ROCKER OIL FEED KIT	GT6 66-73 (1)	62.44	49.95
1-9531	ROCKER OIL FEED KIT	SPITFIRE 73-80 (1)	62.44	49.95



Competition Valves and Valve Springs

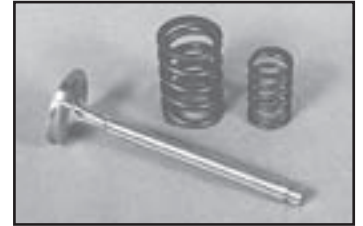

Competition Valves are specially shaped and designed to give maximum fuel flow, once the seats have also been shaped to fit. Valves are sold each. Complete your setup with a new Valve Spring Set. Call or go online and order yours today.

Machining of your cylinder head is required for the installation of your new Valves.

PART	DESCRIPTION AND APPLICATION	REQD	LIST	SELL	
1-5602	INTAKE VALVE	SOLD EACH	SPITFIRE 67-80 (4)	62.44	49.95
1-5612	EXHAUST VALVE	SOLD EACH	SPITFIRE 67-80 (4)	87.44	69.95
1-5613	EXHAUST VALVE	SOLD EACH	GT6 66-73 (6)	74.94	59.95
1-5622	VALVE SPRING SET		SPITFIRE 67-80 (1)	62.44	49.95
1-5624	VALVE SPRING SET		GT6 66-73 (1)	99.94	79.95

Engine Stud and Bolt Kits

GT6 1966-73
Spitfire 1964-80

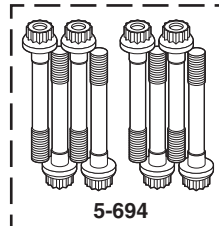

5-694

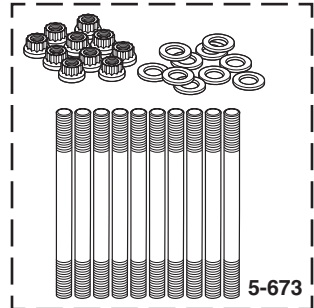

5-673

Professional quality engine hardware from Automotive Racing Products. ARP uses premium grade 8740 chrome moly steel heat treated to a nominal tensile strength of 190,000 psi. These kits are far superior to original fasteners in terms of durability and service life, fully capable of handling the extra stress of high performance engines.

PART	DESCRIPTION AND APPLICATION	REQD	LIST	SELL
5-672	HEAD STUD KIT	GT6 68-73 (1)	199.94	159.95
5-673	HEAD STUD KIT	SPITFIRE 73-80 (1)	124.94	99.95
5-693	ROD BOLT KIT	GT6 66-73 (1)	162.44	129.95
5-694	ROD BOLT KIT	FC30193- SPITFIRE 64-80 (1)	124.94	99.95



Aluminum Flywheel

Your OE Flywheel is very heavy and robs the engine of vital power. This Aluminum Flywheel is lightweight yet has a strong design. This allows the engine to use the horsepower it creates to turn the wheels and not waste it turning a heavy steel flywheel. It is made from 6061 T6 Aluminum with a heat treated 1050 steel friction surface secured with stainless steel rivets. Special Ring Gear is pressed on and secured with grade 10 fasteners. New coarse thread bolts, lock washers and dowels are included to mount your clutch cover.

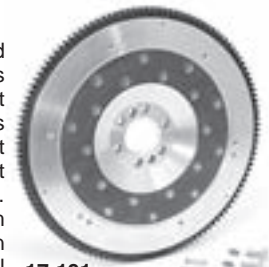

17-191

PART	DESCRIPTION AND APPLICATION	LIST	SELL
17-191	ALUMINUM FLYWHEEL W/RING GEAR	SPITFIRE 1500 73-80	624.94 499.95

